

purified^{air}

REFLOW

RECIRCULATION
AND FILTRATION SYSTEMS

LOCATE COMMERCIAL
KITCHENS **ANYWHERE.**

EXPERTS IN COMMERCIAL KITCHEN FILTRATION

purifiedair®

For over 30 years Purified Air has been a market leader in indoor air quality filtration and filtration and odour control for commercial kitchens.

CONTENTS



02

Introduction	2
How it works	4
Inside the tower	5
Reflow range	6

08

Trusted by	8
Compliant and approved	9
Perfect for	9

11

About us	10
Get in touch	11



LOCATE COMMERCIAL KITCHENS... ANYWHERE.

Our revolutionary recirculation units extract the fumes, grease and odour into our bespoke filtration tower.

There is an increasing demand for unlocking new locations where planning permission may have been refused or where a duct route to outside is simply not possible; Purified Air now has a solution. Our revolutionary recirculation unit extracts the fumes, grease and odour into our filtration tower and returns cleaned air back into the kitchen fully filtered.

BENEFITS

- ✓ Easy installation
- ✓ UK's best filtration
- ✓ Install internally or externally
- ✓ Bespoke service available

5/8 Stage Filtration Process

UKAS Laboratory Tested

No Need For External Ducts

Can Be Sited Remotely

FILTRATION PROCESS

HOW IT WORKS

The extracted air passes through either 5 or 8 stages of filtration, depending on the size of the filtration tower, then exits through the front of the canopy back into the kitchen space via various grille options, fully filtered. We can even site the filtration tower remotely if space is tight on the cook line.

AIRFLOW

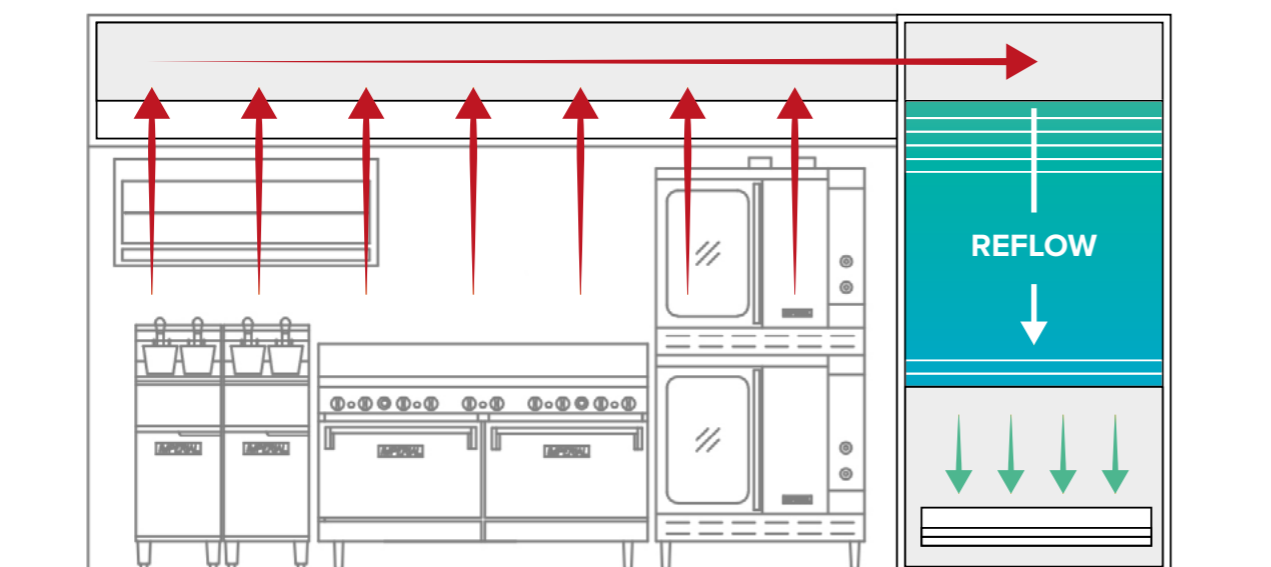

FILTERS REMOVE



Odour



Smoke



Steam



Oil

FILTRATION PROCESS

INSIDE THE TOWER

01 Stainless Steel Baffle
Directly Above Catering Equipment
Prevents flame from traveling up into the extract duct.

03 G4 V Line Panel Filter
Filters medium to fine particulate.

04 Ultima HV Multitwedge High Capacity H10 HEPA Filter
Efficient at filtering ultra fine particulate.

02 Stainless Steel Mesh
Filters larger grease particulate.

05 Carbon Filter Double Pass
Filters the malodorous gasses.

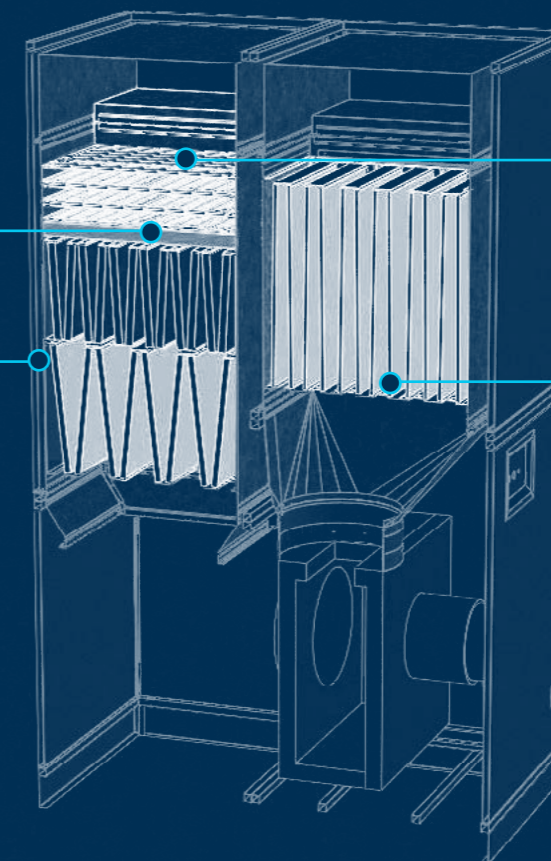

COMPLETE SERVICE PACKAGE



Design



Manufacture



Install



Maintain

REFLOW RANGE

We manufacture three standard units, Reflow 0.9, Reflow 1.5 and Reflow 2.0 handling 0.9m³/s, 1.5m³/s and 2.0m³/s respectively, however bespoke horizontal or vertical units can be provided so no matter what the application or project size we have the solution.

Reflow 0.9

Coverage 0.9m³/s,

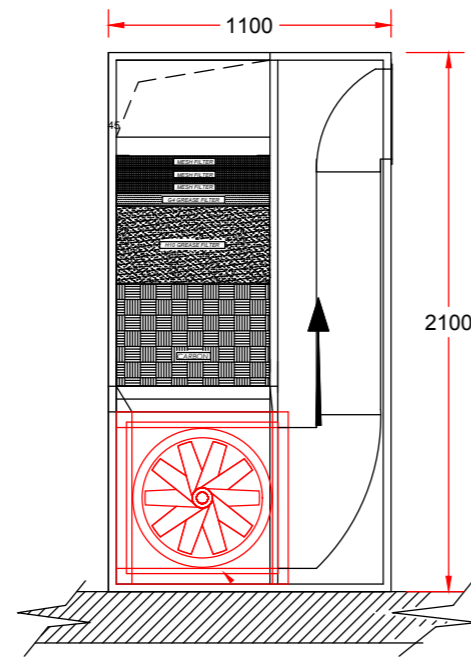

REFLOW 0.9

Electrical Supply	3 Phase - 16 Amp
Max Air Volume	up to 0.9m ³ /sec
Dimensions	W 800 mm
	H 2200 mm
	D 1100 mm
Weight	570Kg inc Filters

Reflow 1.5

Coverage 1.5m³/s

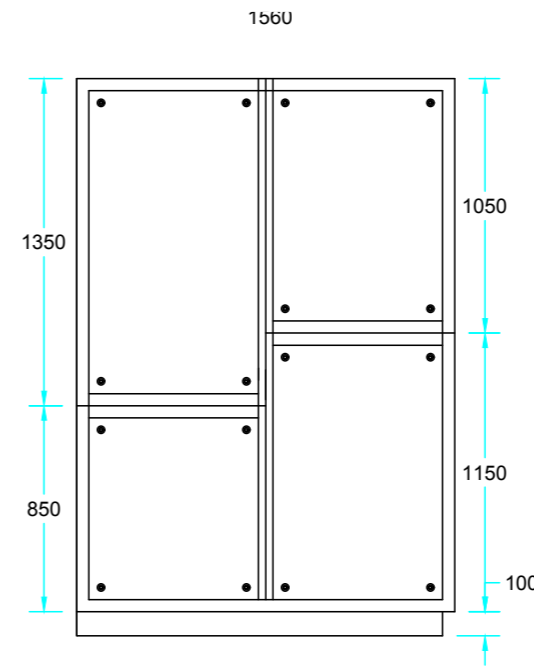

REFLOW 1.5

Electrical Supply	3 Phase - 16 Amp
Max Air Volume	up to 1.5m ³ /sec
Dimensions	W 1100 mm
	H 2200 mm
	D 1560 mm
Weight	750Kg inc Filters

Reflow 2.0

Coverage 2m³/s

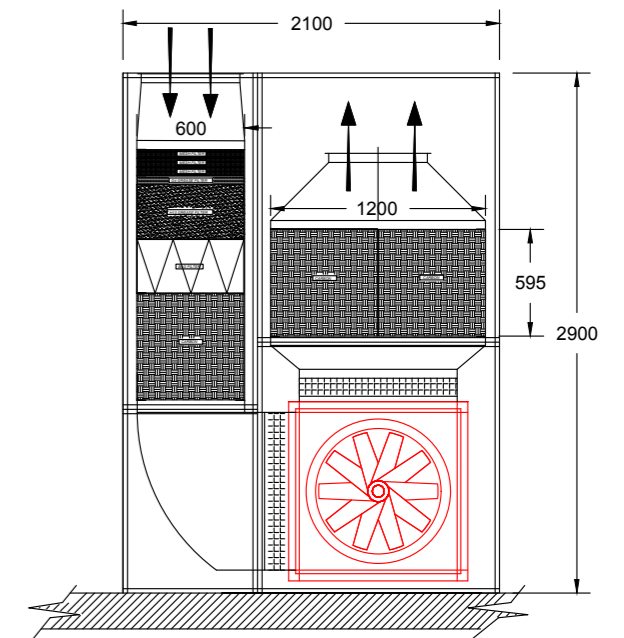

REFLOW 2.0

Electrical Supply	3 Phase - 16 Amp
Max Air Volume	up to 2.0m ³ /sec
Dimensions	W 1400 mm
	H 2900 mm
	D 2100 mm
Weight	1400Kg inc Filters

CONSIDERATIONS

We must stress that this recirculation system is only suitable for commercial kitchens that exclusively use Electric equipment.

We would also recommend that the kitchen space is fitted with air conditioning and ventilation to ensure kitchen temperatures are kept within comfortable levels.



COMPLIANT AND APPROVED



Approved for all Stadiums

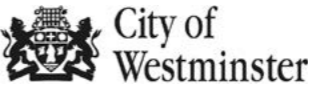

City of Westminster Accepted



Laboratory Tested



Compliant

PERFECT FOR:



Airports



Shopping Centres



Cafes



Stadiums



Restaurants



Catering Canteens

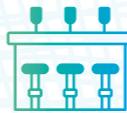

Public Houses



Listed Buildings

TRUSTED BY



We've been working with some of the UK's leading brands to help them install kitchens easily and purify the recirculated air they create.



ABOUT US

Purified Air Ltd. has been striving to find the best and most cost-effective way to filter and control oil, smoke, fat and odour produced by commercial kitchens and residential installation and service since 1984.

Purified Air, which currently supplies systems to many sectoral brands, provides bespoke systems designed dependent on the type of food cooked, the cooking process used, and the volume of the Air extracted. Customers widely use our products within the Fast Food, Casual Dining and Luxury Concept Restaurant (Fine Dining) markets. By working with these variables, we can design and supply some of the best commercial kitchen extractor filter and odour control systems in the world.

GLOBAL COVERAGE

- United Kingdom
- Middle East
- Europe

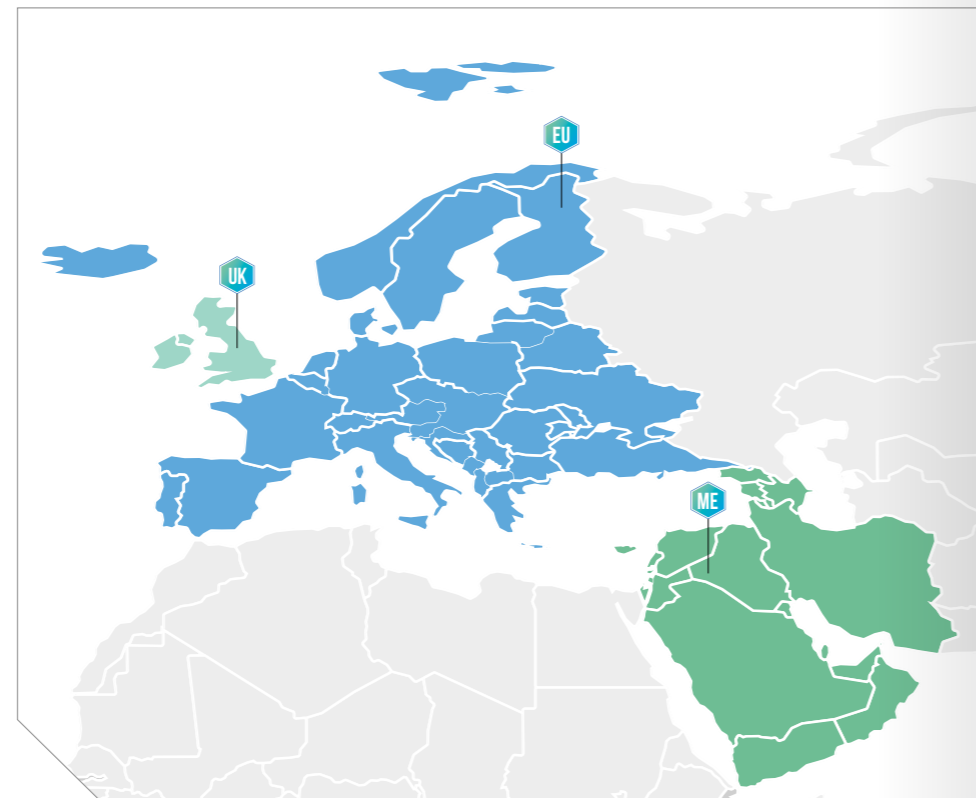

GET IN TOUCH

0800 018 4000

Purified Air Limited, Lyon House
Lyon Road, Romford,
Essex RM1 2BG



purified↔air®